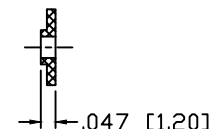
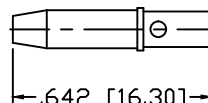
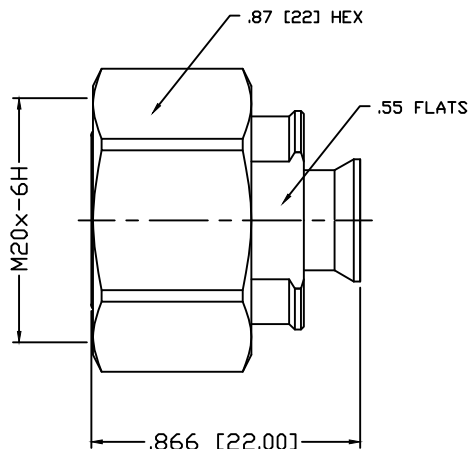
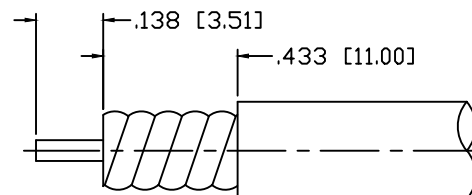

PART NO.

RFD-43MS-HPL

REV	DESCRIPTION	DWN	DATE	APPROVED
-	ENGINEERING RELEASE	CZS	10/12/15	JDMc

SOLDERRECOMMENDED STRIPPING DIMENSIONSSPECIFICATIONS:

IMPEDANCE: 50 OHMS
 FREQUENCY RANGE: DC-6GHz
 INSERTION LOSS: $-.01 \text{ dB} \times \sqrt{\text{FREQUENCY GHz}}$
 VSWR MAX: $<1.15:1 @ \text{DC-3 GHz}$
 3rd ORDER IM: $\leq -160 \text{ dBc}$
 INSULATION RESISTANCE: 5000M Ω
 OPERATING TEMPERATURE: -30°C TO $+125^{\circ}\text{C}$

CUSTOMER
OUTLINE DRAWINGALL DIMENSIONS
ARE REFERENCE ONLYUNLESS OTHERWISE SPECIFIED:
DIMENSIONS ARE IN INCHES
AND [MILLIMETERS]

DRAWN	C. ZUNIGA	10/12/15
CHECKED		
ORJ DRAWN	C. ZUNIGA	10/12/15

**RoHS
COMPLIANT**

PROPRIETARY AND CONFIDENTIAL
 THIS DRAWING CONTAINS
 INFORMATION PROPRIETARY TO
 RF INDUSTRIES. ANY
 UNAUTHORIZED USE OF THIS
 DRAWING IS EXPRESSLY
 PROHIBITED WITHOUT WRITTEN
 PERMISSION FROM RF
 INDUSTRIES. ANY VIOLATION IS
 PUNISHABLE UNDER U.S.
 COPYRIGHT LAWS.

RFconnectors

7610 MIRAMAR RD.
 SAN DIEGO, CA 92126
 (858) 549-6340
 (858) 549-6345 FAX

4.3/10 MALE
FOR SPP-250LLPL

SIZE	CABLE GROUP	DWG NO.	REV
A	N/A	RFD-43MS-HPL	—
SCALE:	ENGINEERING ID:	SHEET 1 OF 1	
NTS	001787		

#	DESCRIPTION	QTY	MATERIAL	FINISH
7	SHELL	1	BRASS	WHITE BRONZE
6	RETAINING RING	1	BeCu	WHITE BRONZE
5	O-RING	1	S.I. RUBBER	----
4	SPACER	1	PTFE	----
3	INSULATOR	1	PTFE	----
2	PIN	1	BRASS	SILVER
1	BODY	1	BRASS	WHITE BRONZE