

PART NO.		RFW-5580-XX		
REV	DESCRIPTION	DWN	DATE	APPROVED
-	ENGINEERING RELEASE	CZS	09/22/15	JDMc

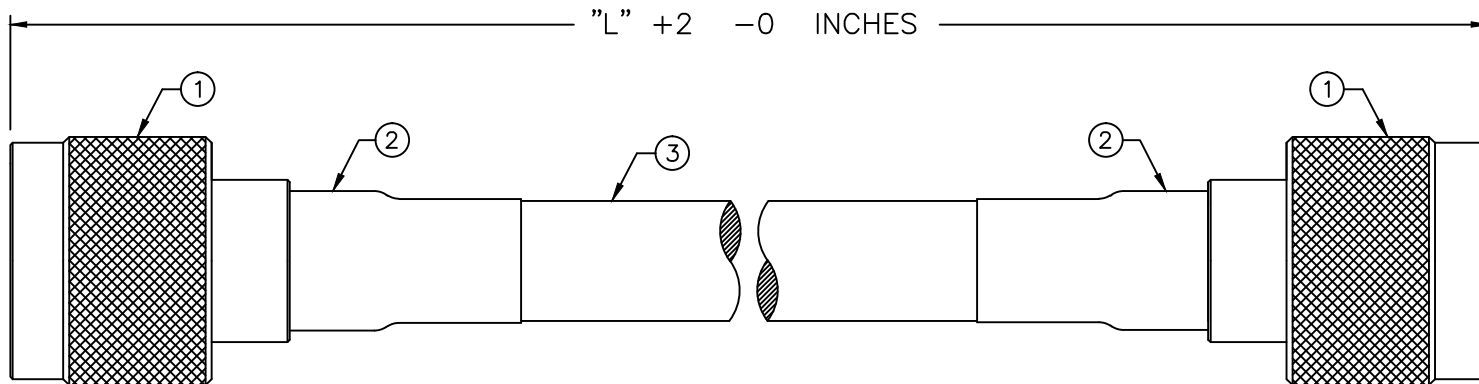

RFW-5580-XX
 [“L”] LENGTH IN INCHES
 SPECIFIC PART NUMBER
 CABLE ASSEMBLY DESIGNATOR

STANDARD CABLE LENGTHS [“L”]:	CABLE LENGTHS [“L”]:
-12 [1 FOOT]	-144 [12 FOOT]
-24 [2 FEET]	-180 [15 FEET]
-36 [3 FEET]	-216 [18 FEET]
-48 [4 FEET]	-300 [25 FEET]
-60 [5 FEET]	-600 [50 FEET]
-72 [6 FEET]	-900 [75 FEET]
	-1200 [100 FEET]
	-1800 [150 FEET]

CUSTOMER
 OUTLINE DRAWING
 ALL DIMENSIONS
 ARE REFERENCE ONLY
 UNLESS OTHERWISE SPECIFIED:
 DIMENSIONS ARE IN INCHES
 AND [MILLIMETERS]

PROPRIETARY AND CONFIDENTIAL
 THIS DRAWING CONTAINS
 INFORMATION PROPRIETARY TO
 RF INDUSTRIES. ANY
 UNAUTHORIZED USE OF THIS
 DRAWING IS EXPRESSLY
 PROHIBITED WITHOUT WRITTEN
 PERMISSION FROM RF
 INDUSTRIES. ANY VIOLATION IS
 PUNISHABLE UNDER U.S.
 COPYRIGHT LAWS.

RFconnectors
 DIVISION OF RF INDUSTRIES, LTD.
 7610 MIRAMAR RD.
 SAN DIEGO, CA 92126
 (858) 549-6340
 (858) 549-6345 FAX

**N PLUG CRIMP TO
 N PLUG CRIMP**

3	LMR-400	1	CABLE	---
2	ST-P0250A-K	2	TUBING	HEAT SHRINK
1	RFN-1006-3I	2	N PLUG CRIMP	SILVER
#	PART NUMBER	QTY	DESCRIPTION	FINISH

DRAWN	C. ZUNIGA	09/22/15
CHECKED		
ORJ DRAWN	C. ZUNIGA	09/22/15

SIZE	CABLE GROUP	DWG NO.	REV
A	I	RFW-5580-XX	—
SCALE:	ENGINEERING ID:	SHEET 1 OF 1	
NTS	000000		